



G-OP-WPIR-W and -U

OUTDOOR DUAL TECHNOLOGY DETECTOR
INSTALLATION AND USE MANUAL

ver.: 2019-06-11_1_fr

G-OP-WPIR-W and U is a curtain detector for protection of doors and windows. This device has double technology detection: it integrates two infrared passive modules and a pulsed microwave module, designed to obtain a very narrow detection beam. The alarm is generated only when both technologies detect at the same time, avoiding false alarms. The device is provided with automatic temperature compensation of its parameters. Its dimensions – particularly reduced in height and width – allow an easy installation in the narrow spaces available on doors and windows. The sensor is protected from removal risk, thanks to an integrated anti-removal system.

READ CAREFULLY THIS MANUAL BEFORE INSTALL YOUR NEW ALARM SYSTEM. KEEP THIS MANUAL FOR FUTURE REFERENCE.

ONLY QUALIFIED TECHNICIAN MUST INSTALL THIS DEVICE. INSTALLER MUST FOLLOW CURRENT REGULATIONS.

THE MANUFACTURER SHALL NOT BE LIABLE FOR ANY IMPROPER USE OF THE PRODUCT, INCORRECT INSTALLATION OR FAILURE TO COMPLY WITH INSTRUCTIONS OF THIS MANUAL AND THE LAW REGARDING ELECTRICAL SYSTEMS.

DETECTION AREA

A

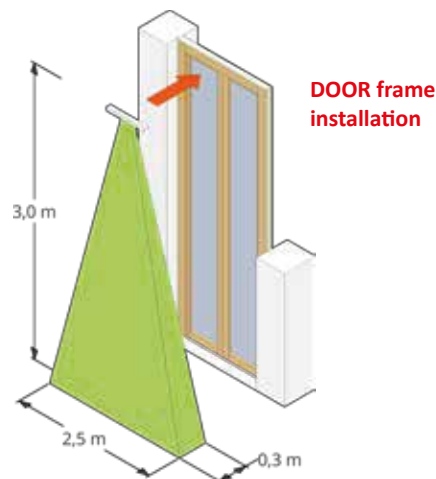
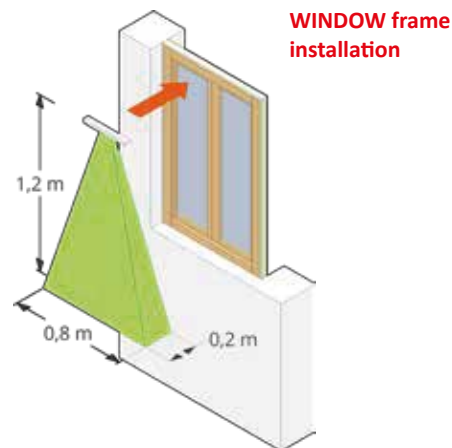

TECHNICAL

	G-OP-WPIR-W (wired)		G-OP-WPIR-U (Universal)	
Power supply	8 ÷ 14 V _{DC}		n. 1 lithium battery pack, 6 V	
Absorption *	Stand-by: about 8 mA Alarm: about 5,5 mA (LED off)		Stand-by: about 25 µA Alarm: about 5 mA	
Autonomy (estimated) **	-		About 2 years	
Stabilization Time (at power-up)	About 120 seconds		About 120 seconds	
Quiet Time between detections ***	-		About 30 seconds	
TEST mode lasting	-		5 minutes (at the end, the sensor backs to NORMAL mode even if J.MODE = CLOSED)	
Detection technologies	Infrared (double head) + Pulsed microwave		Infrared (double head) + Pulsed microwave	
Microwave frequency / working mode	24 GHz / Pulsed		24 GHz / Pulsed	
Detection Area (H x W x D) *	Door: 3 x 2,5 x 0,3 m Window: 1,2 x 0,8 x 0,2 m		Door: 3 x 2,5 x 0,3 m Window: 1,2 x 0,8 x 0,2 m	
Radio working frequency	-		-	
Radio range	-		-	
Radio signalling	-		-	
Wired outputs	OptoMOS, N.C. type (open if power off) Max 60V / 100mA / 16Ω Insulation: 1500V	Alarm Tamper	OptoMOS, N.C. type (close if power off) Max 60V / 75mA / 10Ω Insulation: 1500V	Alarm Tamper Low Battery
LED signalling	2 red LED (IR heads detection) 1 green LED (microwave detection) 1 blue LED for alarm		2 red LED (IR heads detection) 1 green LED (microwave detection) 1 blue LED for alarm	
Temperature **** / Humidity	-40 ÷ +70 °C / 95 %		-40 ÷ +70 °C / 95 %	
Case	ABS antiUV		ABS antiUV	
Dimension (H x W x D)	40 x 330 x 30 mm		40 x 330 x 30 mm	
Internal space for transmitter (H x W x D)	-		20 x 70 x 30 mm	

* All the data are approximate, for sensor in NORMAL mode at operating temperature of 21 °C
** Mean value for 50 detections-alarms/day + supervision
*** Sensor working in NORMAL mode
**** Automatic parameters adjustment with temperature, linear compensation

BATTERY DURATION (ESTIMATED) IS PROPORTIONAL TO:

- ⊗ HEAT CYCLES OF THE BATTERY WHICH AFFECT CHARGE CAPACITY AND DURATION
- ⊗ WORKING TEMPERATURE OF THE BATTERY (E.G.: AT TEMPERATURE LOWER THAN 0°C THE BATTERY DURATION MAY DECREASE OF 50 %)
- ⊗ NUMBER OF DETECTIONS TO WHICH THE SENSOR IS SUBJECT: IF THE SENSOR IS INSTALLED IN HIGH FREQUENCY OF PASSAGE, THE BATTERY DURATION WILL DECREASE DRAMATICALLY

THE MAX RANGE DEPENDS SIGNIFICANTLY ON ENVIRONMENT TEMPERATURE.

INSTALLATION (PLACEMENT)

The detector must be installed only in horizontal position over the opening to protect, oriented downward (fig. B-1 and B-2).

B

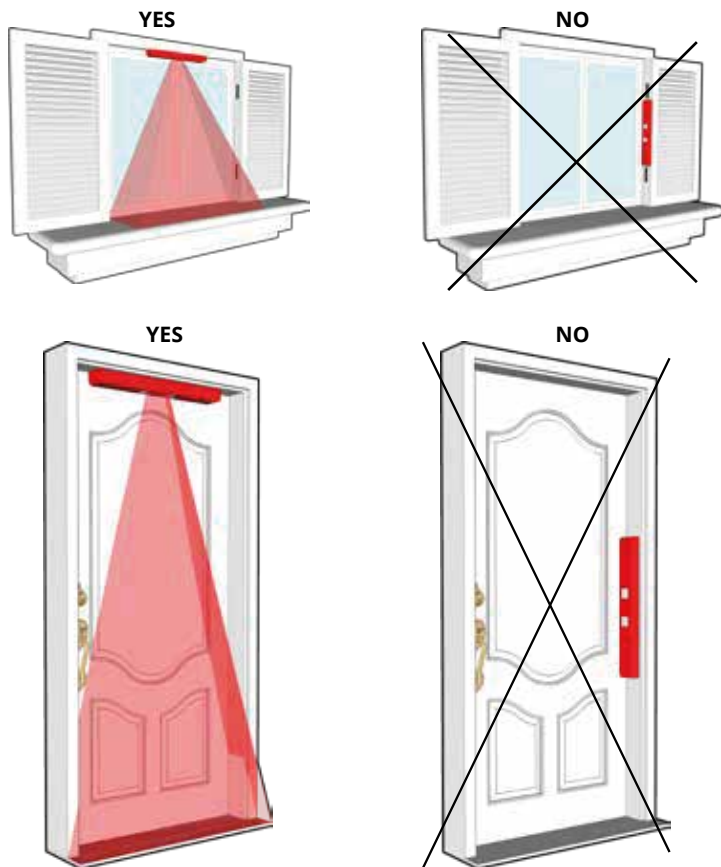

E

To open the sensor, remove the screw and lift the cover (fig. E). If the anti-opening tamper is active, the sensor transmits alarm.

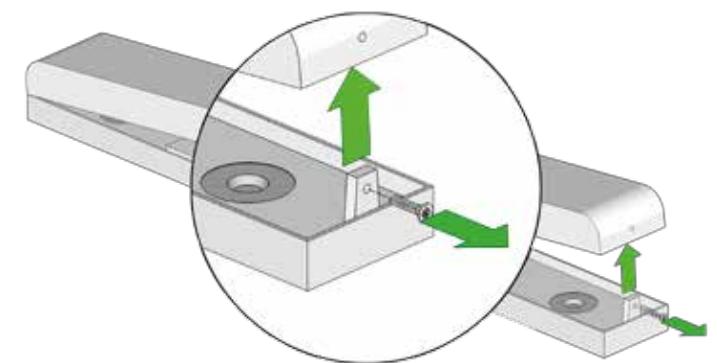

DO NOT CUT OR PUNCH

Push the cables through the cable gland until it breaks: in this way the sheath will open just where necessary, bonding to the cables and ensuring a higher protection.



The detector must be installed with the side that presents the LEDs towards OUTSIDE (garden, backyard, balcony...) and the opposite side towards INSIDE (door or window) to protect:

C

LED side: towards outside

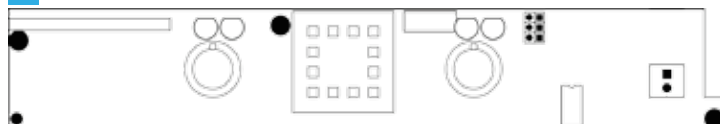

PRECAUTIONS

- ④ Detector must be installed protected from the elements. Install protected from direct rain.
- ④ This sensor has been designed to guarantee a very high immunity to light interference; however, a very bright light can produce a range decrease. It is recommended to pay attention during the installation and avoid, as much as possible, that direct or reflected solar light or very intense lights are oriented towards the two sensitive elements.
NEVER POINT the sensor directly towards reflective surfaces, in order to avoid unwanted detections. Typical examples of reflective surfaces are: windows, glass walls, water puddles, wet roads, smooth concrete surfaces, paved roads. The reflection level of these surfaces is not at 100%, anyway if the source of heat is very strong, the reflection may be enough to alarm the sensor.
- ④ Infrared detector is sensitive to the "amount of heat" produced by a moving body. The maximum range of the sensor (measured in meters) is referred to a human body. However the same "amount of heat" may be produced by a smaller body at lower distances, or by a larger one at greater distances. It should be considered therefore that the range of any passive infrared sensor is a RELATIVE measure (referring to a human body) and NOT ABSOLUTE.

D



- ④ The sensor is highly immune to false alarms caused by presence of regular mosquito nets or rollers within the detection area, provided that nets are always taut and rollers are fully raised or lowered. If these indications are not met, increase both the risk of false alarms and the battery consumption for G-OP-WPIR-U.
- ④ Do not point the sensor towards unstable objects, such as: bushes, flags, tree branches, clothes hung, etc. This avoid unwanted detections.
- ④ During adjustment, perform as detection tests as necessary to obtain a correct sensor behavior.
- ④ The sensor may detect pets (no pet-immune function).

F

G-OP-WPIR-W (wired)

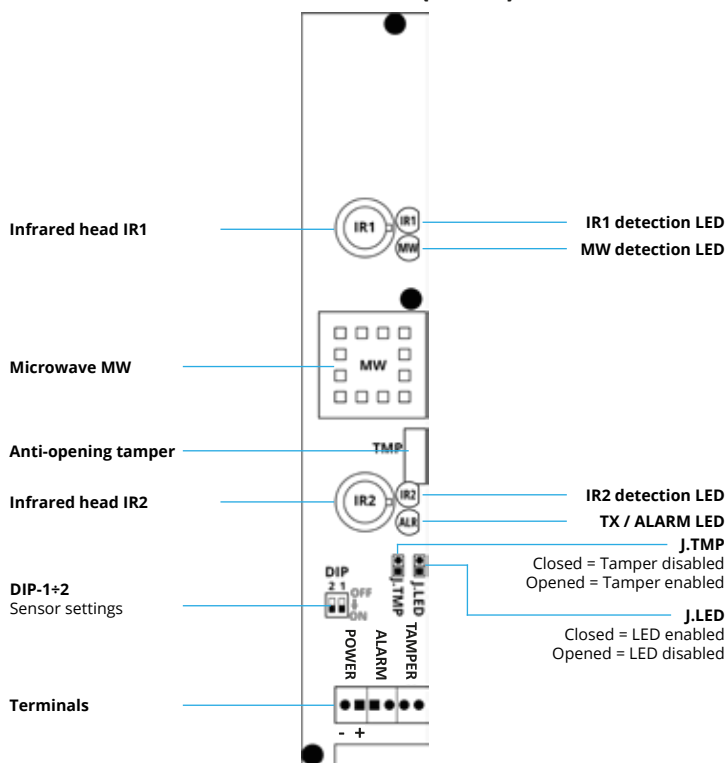

DIP-SWITCH

		OFF	ON
DIP1	Anti-removal	Active	Excluded
DIP2	Detection type	Window (low sensitivity)	Door (high sensitivity)

It is recommended to disable the LEDs (J.LED = OPENED) after the test.

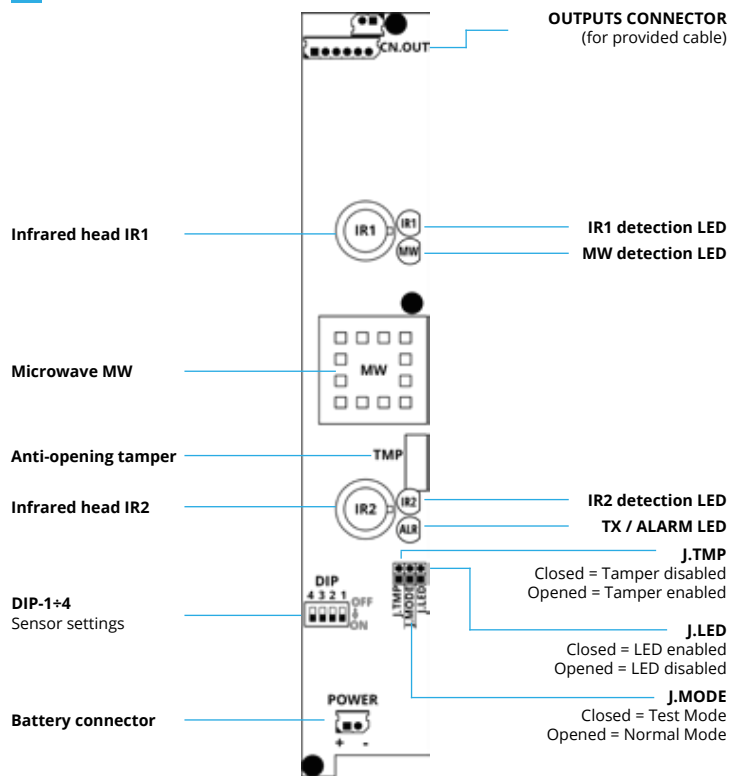

DIP-SWITCH

		OFF	ON
DIP1	Anti-removal	Active	Excluded
DIP2	Detection type	Window (low sensitivity)	Door (high sensitivity)
DIP3	Not used	Leave OFF	
DIP4	Not used	Leave OFF	

It is recommended to disable the LEDs (J.LED = OPENED) after the test to increase the battery life.

TEST AND NORMAL MODES (ONLY G-OP-WPIR-U)

G-OP-WPIR-W works only in TEST mode.

With J.MODE jumper is possible to set the sensor in TEST or NORMAL mode:

④ TEST mode: J.MODE = CLOSED

The sensor transmits / signals alarm at each detection. This mode allows the installer a correct tuning of the detector.

To exit from TEST mode and back to NORMAL, open the J.MODE jumper: some seconds after last detection, the sensor signals the exit by sequentially turning on the LEDs (round trip).

The sensor exit automatically from TEST after about 5 minutes – even without opening the J.MODE jumper. The automatic exit is also signalled by the sequential turning on of the LEDs.

If necessary to increase the TEST mode time, simply open and close the J.MODE jumper and wait for the confirmation (the LEDs blink).

The TEST mode is set as default.

④ NORMAL mode: J.MODE = OPENED

It's the mode the detector MUST be set when in normal working. In this mode – after last detection and alarm transmission – the detector wait for a “quiet time” before to consider a new intrusion (alarm).

If during this time there is no detection the sensor will back ready to a new detection, otherwise the quiet time is extended.

The quiet time is about 30 seconds (not changeable).

The NORMAL mode allow a lower consumption and a longer battery life.

Output Cable
(connect to the transmitter)

Low Battery
(yellow wires)

Tamper
(white wires)

Alarm
(red wires)

Connector
(connect to CN.OUT)

Transmitter Space
(maximum dimension)

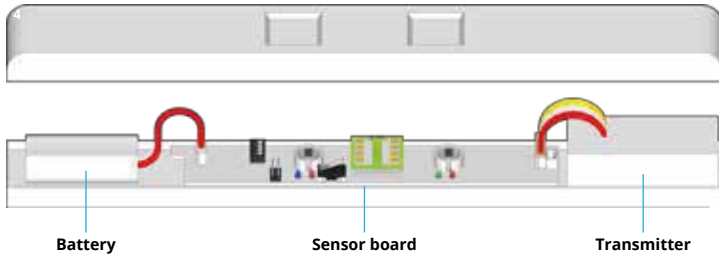
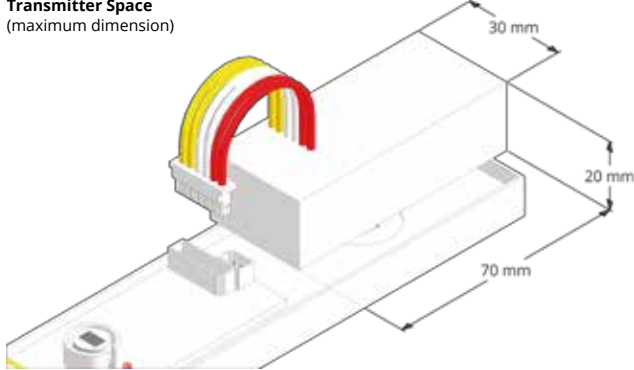

POWER-ON

BEFORE POWER THE SENSOR

If the sensor is already powered (or at battery change), before proceed it is necessary to disconnect the battery, open the jumper **J.TMP** and hold the tamper switch for about 10 seconds: in this way the circuit will be completely discharged and will be possible to start-up the sensor correctly.

G-OP-WPIR-W and U

Power the sensor only after all the wiring is completed.

When the sensor is powered, the LEDs light on in sequence for some seconds: the sensor starts the **"Stabilisation period"**

The **"Stabilisation period"** takes about **2 minutes** (the infrared and microwave LEDa light on in case of detection)

At the end of the stabilization time, the sensor is ready for use.

ANTI-REMOVAL TAMPER (INCLINOMETER)

The sensor is provided with an anti-removal function (that can be activated with **DIP1**) which establishes whether the sensor is moved from the installing position.

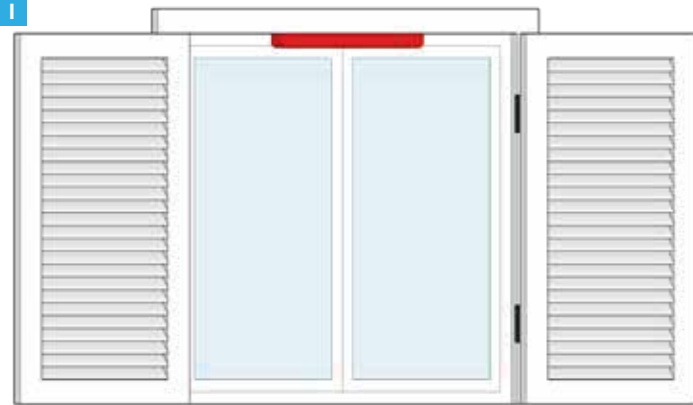

This function is activated just when the sensor is in the **HORIZONTAL** position and afterwards it is inclined. In order to activate the removal detection, it is necessary to put the sensor horizontally: from now on the anti-removal is activated; if the sensor moves it indicates tamper alarm.

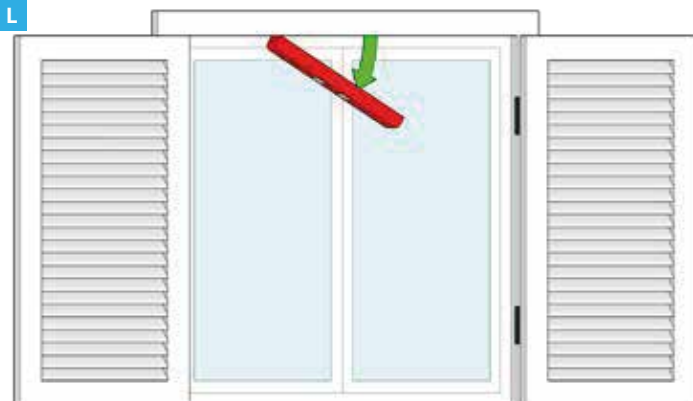

BATTERY (ONLY G-OP-WPIR-U)

LOW BATTERY

When the battery is low, the sensor activates the "low battery" output (model -Universal).

The low battery alert low battery output is activated after three alarm or supervision transmissions (if in test, it is sent after each transmission). Depending on the control panel or receiver model, the alert is visualized on display or LED.

Note: the low battery alerts will continue until the battery is replaced.

BATTERY REPLACEMENT

When the battery must be replaced:

- ④ Disconnect the old battery
- ④ Open the jumper **J.TMP**, then press and hold the tamper switch for at least 3 seconds (circuit discharge)
- ④ Connect the new battery (see the par. "Power on")

Caution, the device works by lithium battery.

Handle with care. Risk of explosion and fire.

Do not dispose batteries in fire, do not weld or damage the battery.

Replace the battery exclusively with one of the same type.

Follow the polarity indicated in the instructions.

Have the battery replaced by a qualified technician.

Dispose of empty batteries following the current regulations, even in case of equipment disposal.

In case of leakage, protect your hands with special gloves.